



www.hy-lok.com

Catalog No. H-120MV
Jan. 2011

M Series

Instrument Manifolds and Gage Valves

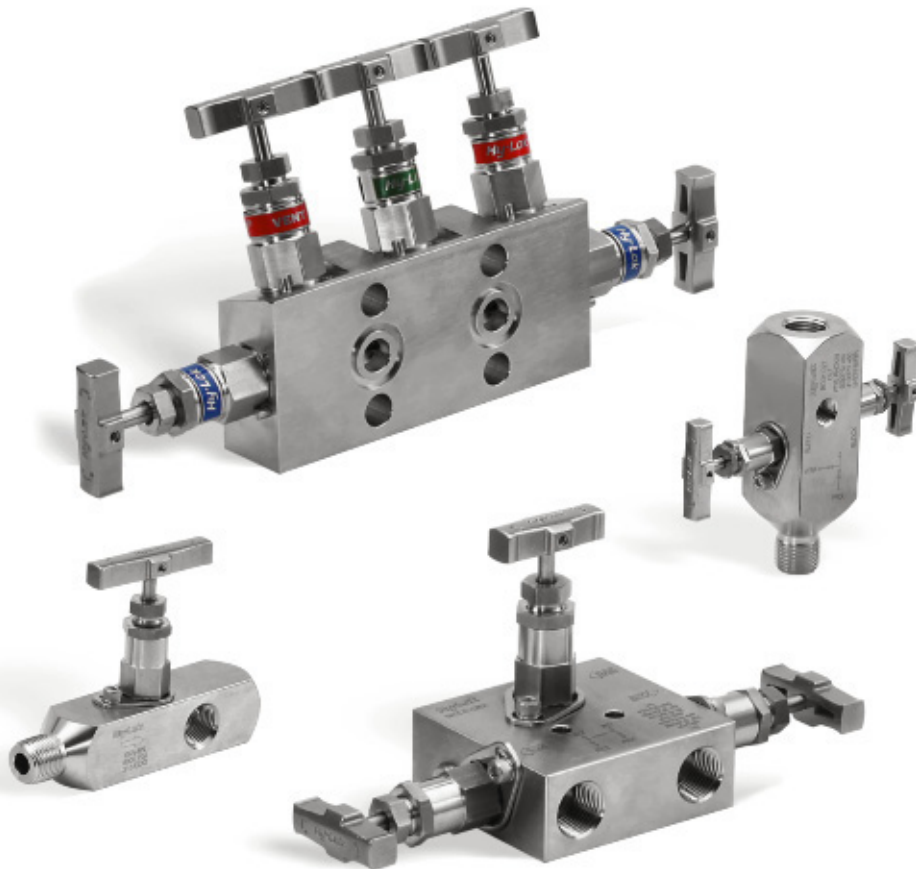

HY-LOK CORPORATION

©2002, 2003, 2006, 2011 HY-LOK CORPORATION All rights reserved

General

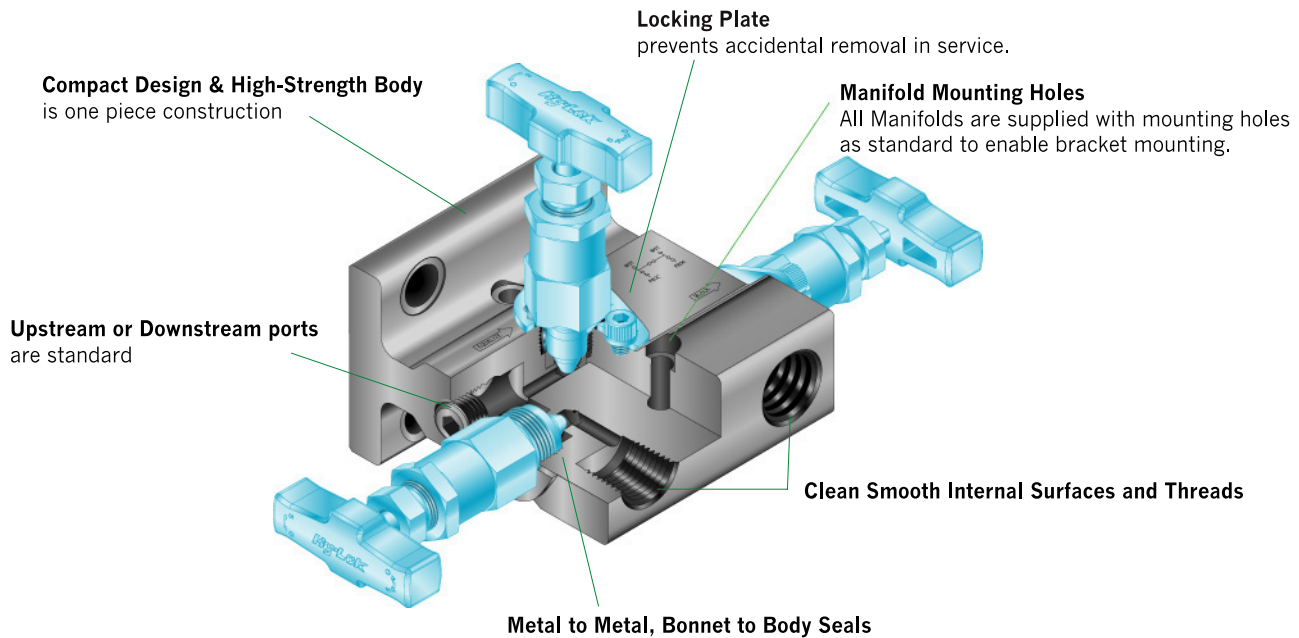

Features

- Pressure rating up to 6000psig (410 bar) @ 100°F (38°C)
- Temperature rating up to 1200°F (648°C) with optional Grafoil packing
- Flange seal grooves meet the design requirements of MSS-SP-99
- Body materials available in 316 stainless steel, carbon steel, alloy 400
- 100% factory tested

Technical Data

Packing and Body Material vs Temperature and Pressure Rating

Packing Material	Body Material	Temperature Range	Pressure Rating @ 100°F	Pressure Rating @ Max. Temperature
PTFE	Stainless Steel	-65 °F ~ 450 °F (-54 °C ~ 232 °C)	6000 psig	4130 psig @ 450 °F (285 bar @ 232 °C)
	Carbon Steel	-20 °F ~ 350 °F (-29 °C ~ 176 °C)	6000 psig	5230 psig @ 350 °F (360 bar @ 176 °C)
	Alloy 400	-65 °F ~ 450 °F (-54 °C ~ 232 °C)	5000 psig	3970 psig @ 450 °F (274 bar @ 232 °C)
Grafoil	Stainless Steel	-65 °F ~ 1200 °F (-54 °C ~ 648 °C)	6000 psig	1715 psig @ 1200 °F [ⓐ] (118 bar @ 648 °C)
	Carbon Steel	-20 °F ~ 350 °F (-29 °C ~ 176 °C)	6000 psig	5230 psig @ 350 °F (360 bar @ 176 °C)
	Alloy 400	-65 °F ~ 500 °F (-54 °C ~ 260 °C)	5000 psig	3960 psig @ 500 °F [ⓑ] (273 bar @ 260 °C)

ⓐ 1715 psig @ 1200°F (118 bar @ 648°C) for female NPT to female NPT manifold
 1715 psig @ 1000°F (118 bar @ 537°C) for flange connection manifold

ⓑ Not applicable over 500°F (260°C)

Note - Optional vitor® flange seals available, Minimum temperature -20°F (29°C)

Testing

- Each instrument manifold is tested with nitrogen @ 1000 psig (69 bar) to max. leak rate of 0.1 SCCM.
- Hydrostatic shell test is performed at 1.5 times the working pressure as an option.
- Other tests are available upon request.

Sour Gas Service

Valves are available in materials which comply with standard NACE MR-01-75 latest revision relating to metallic materials offering optimum resistance to sulfide stress cracking

Notice

When you operate the valve initially or during operating the valve, you may require tightening the packing bolt. And you re-operate the valve initially after quite a long time, you may feel quite a high operating torque.

Bonnet Features

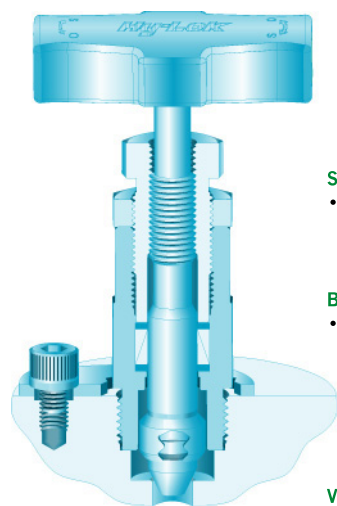

MBV
Orifice 6.4

Stem Threads
• are hard chrome-plated and lubricated for maximum service life

Back Seating
• provides anti-blow out of stem and secondary stem seal

Variety of Stem Tips
• include non-rotating Vee (standard) and Ball tip (optional)

Robust Stainless steel Bar Handle

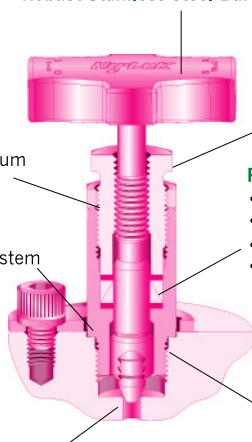

MAV
Orifice 3.2

Packing Bolt
• allows easy packing adjustment for leaktight.

Packing
• is below stem threads construction.
• isolate stem thread from process.
• prevents stem lubricant washout.
• is PTFE standard with reinforced packing washer and Grafoil available upon request

Metal Seal Construction
• ensures safety

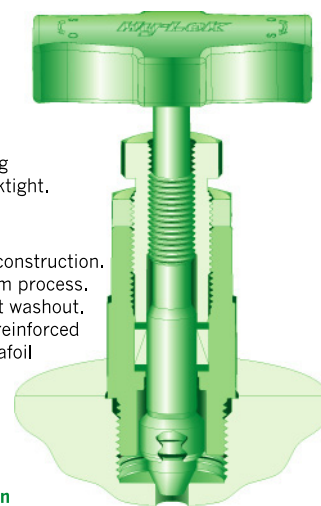

MCV
Orifice 5.0

* **Note** : Bonnet selection by color after this page

Materials of Construction

Description	Material / ASTM Specification		
	Body Material*		
	316SS / A479 / A182	C. Steel / A105	Alloy 400 / B564
2A* Vee tip	TP630 / A564		N05500 / B865
2B* Ball tip			
3* Stem	TP316 / A479		N04400 / B564
4* Bonnet	TP316 / A479	C. Steel / A105	
5A* Stem Packing	PTFE		
5B* Stem Packing	Graphite		
6* Packing Washer	Reinforced PTFE		
7 Lock nut	TP316 / A479		
8 Packing bolt	TP316 / A479		
9 Handle	Stainless Steel	Aluminium	Stainless Steel
10 Set screw			
11 Locking Plate	Stainless Steel		
12 Spring Washer			
13 Bolt			

Note "*" marked are wetted parts.

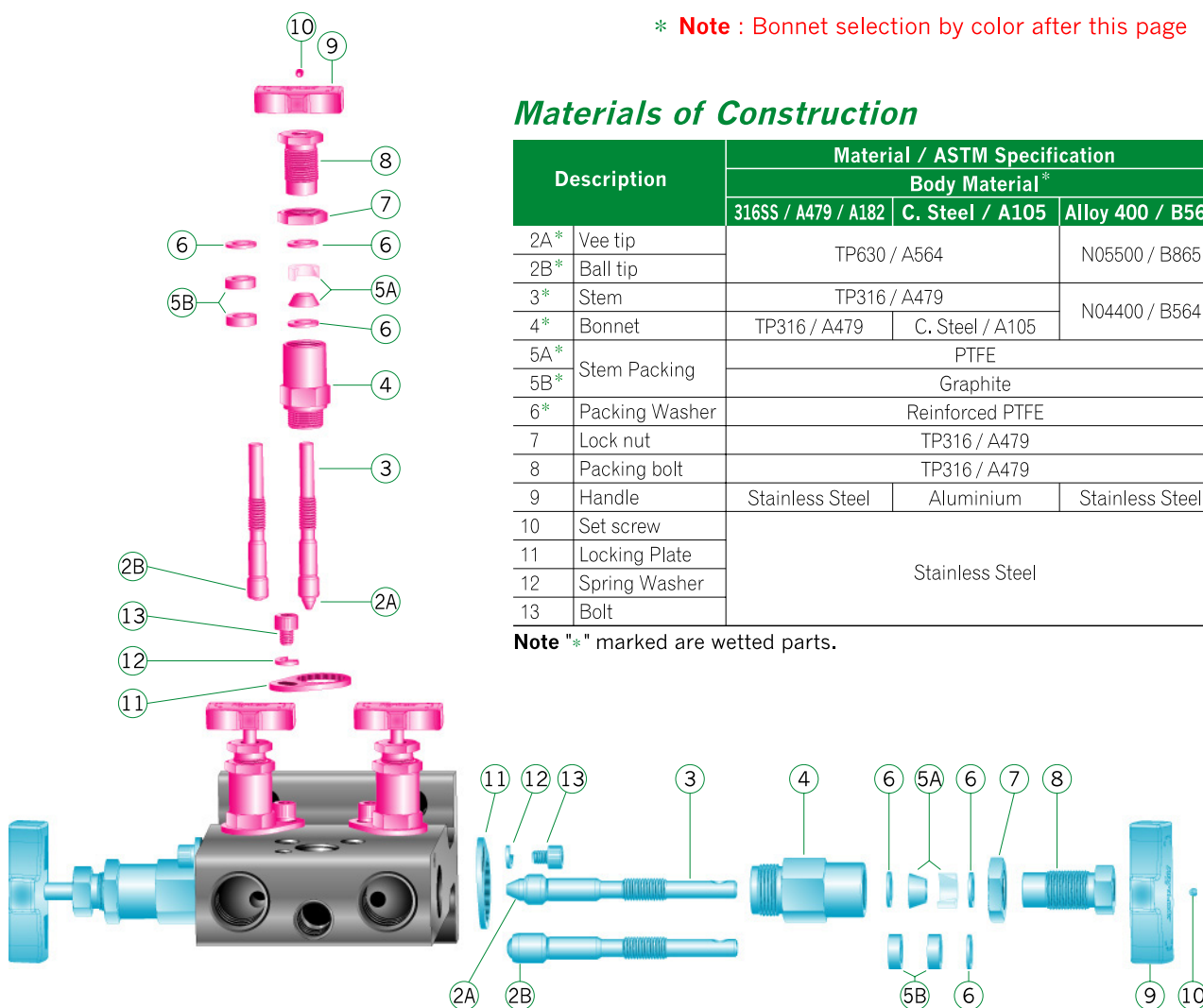

General Page 2,3

Remote Mounting

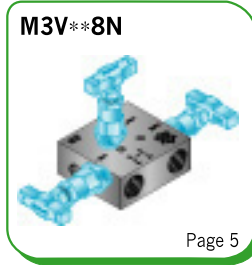

Direct Mounting

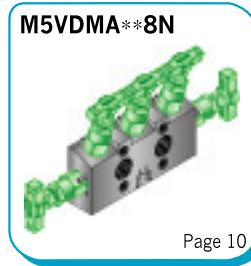
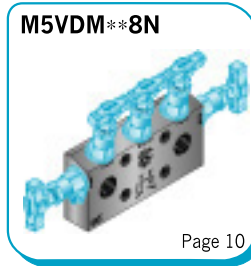
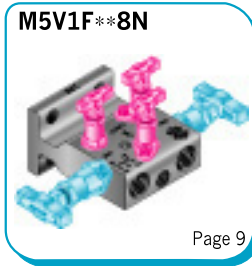
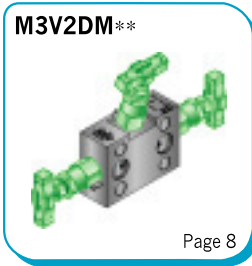
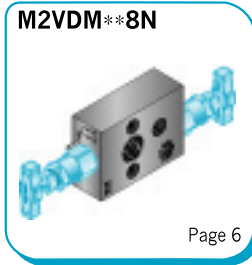
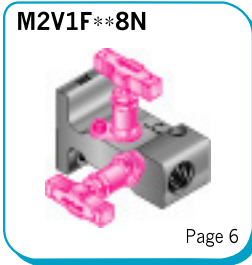

Gage / Root Valve

Accessories & Maintenance Kits



Ordering Information Page 13

Remote Mounting

2-Valves Block
M2V ** 8N
 0.8 kg (1.8 lb)

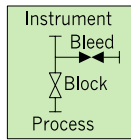

2-Valves Vertical
M2VV ** 8N
 0.9 kg (2.0 lb)

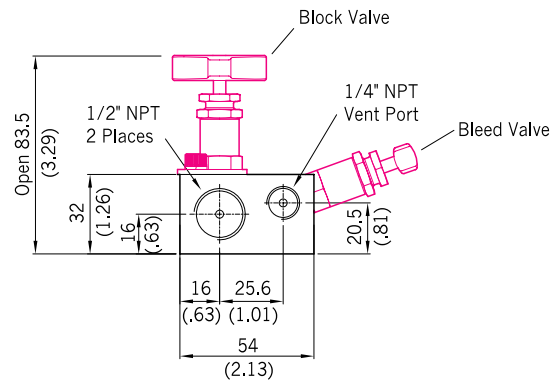
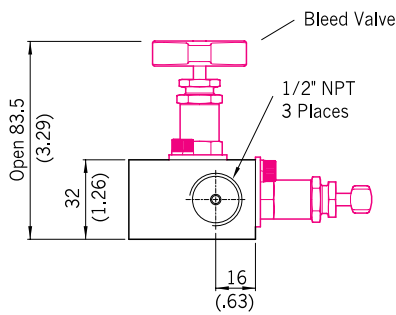
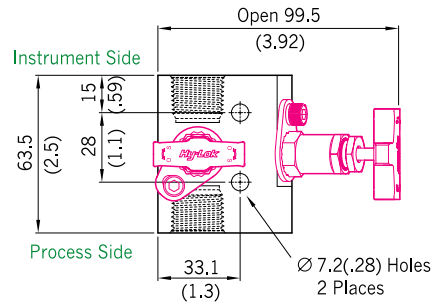
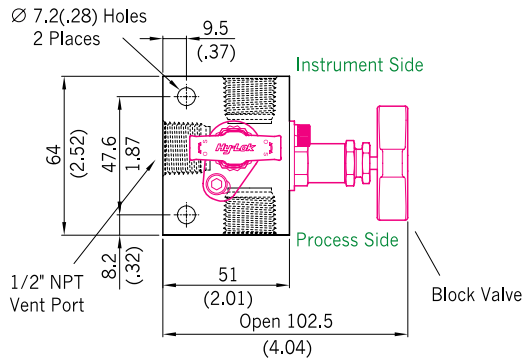
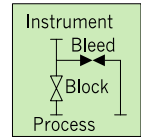

3-Valves Block
M3V ** 8N
 2.0 kg(4.4 lb)

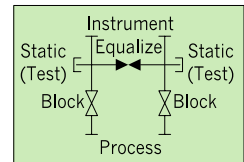

Side View

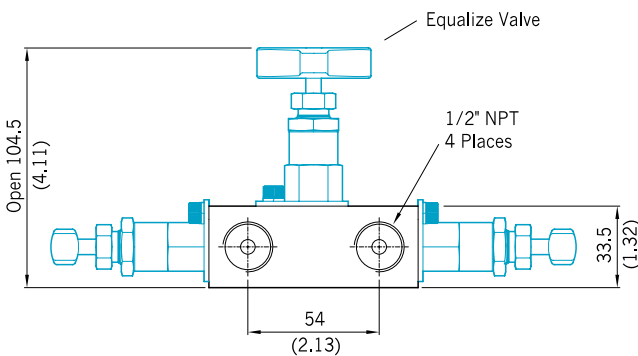

Top View

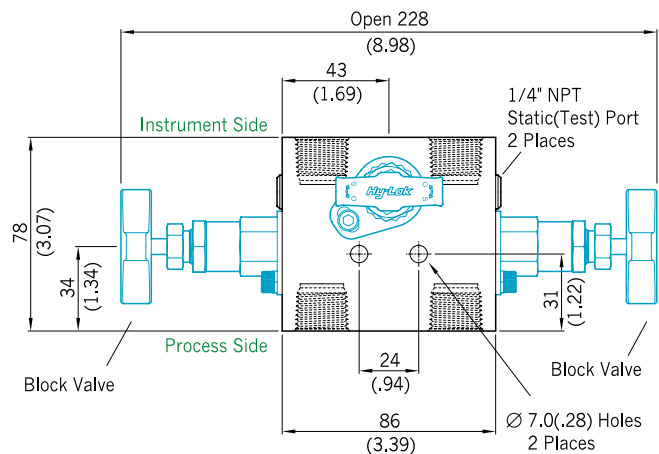

All dimensions are in millimeters(inches) reference only, subject to change.

Instrument Manifold

5-Valves Block

M5V ** 8N

2.2 kg (4.9 lb)

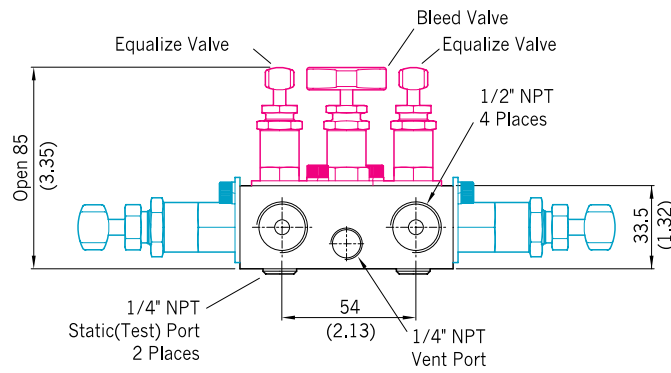
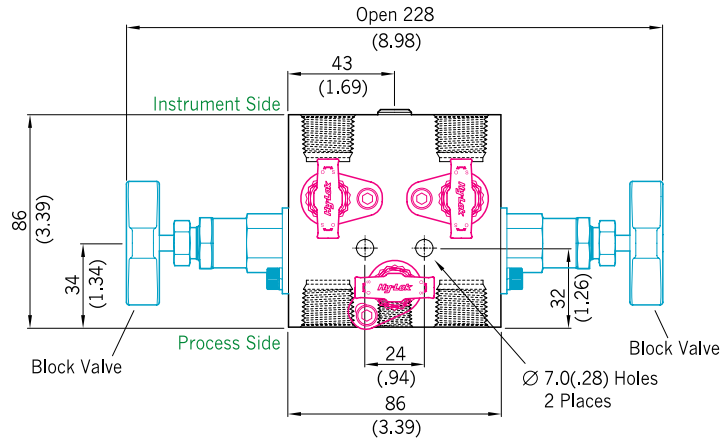
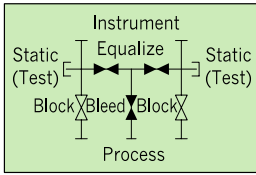

Direct Mounting

2-Valves Single Flange

M2V1F ** 8N

1.0 kg (2.2 lb)

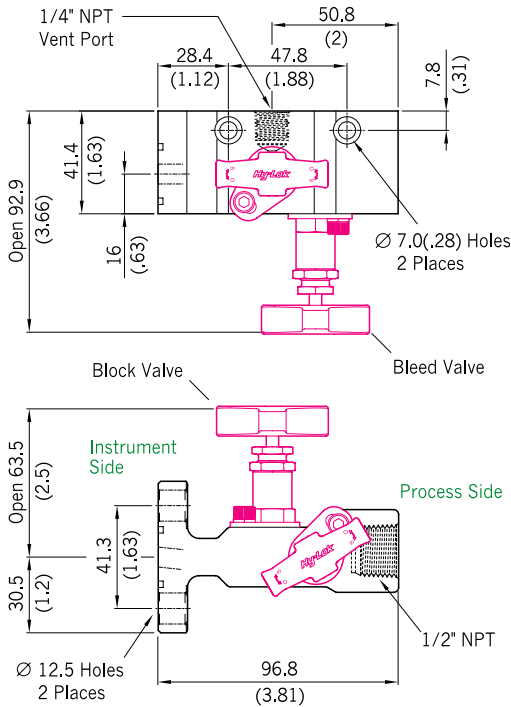
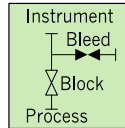

2-Valves Single Block Flange

M2VDM ** 8N

1.6 kg (3.5 lb)

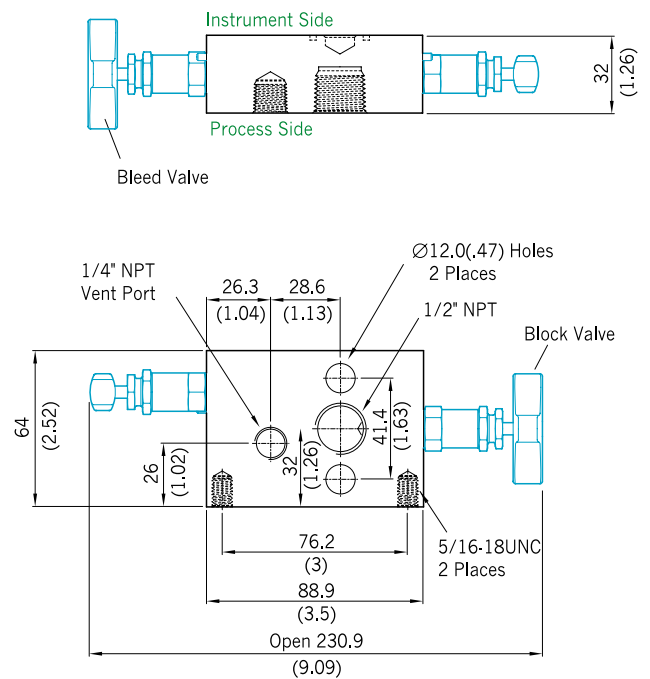
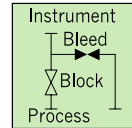

All dimensions are in millimeters(inchs) reference only, subject to change.

3-Valves Single Flange
M3V1F ** 8N
 2.2 kg (4.9 lb)

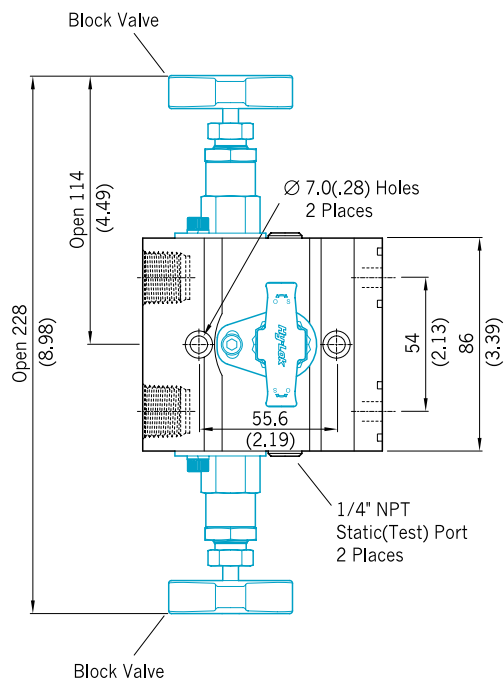

3-Valves Dual Flange
M3V2F **
 2.5 kg (5.5 lb)

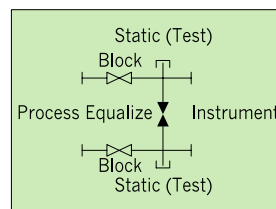
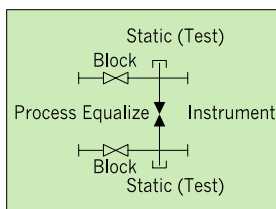
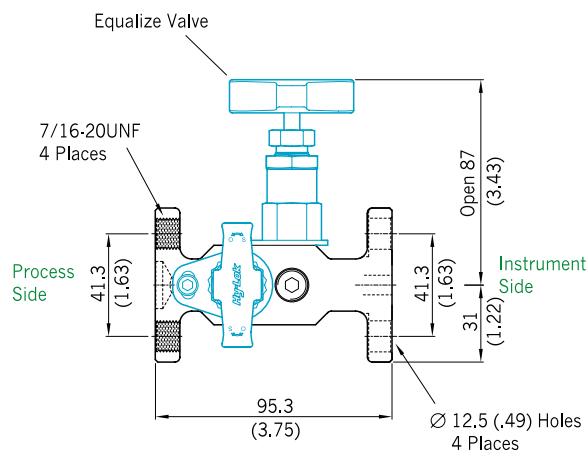
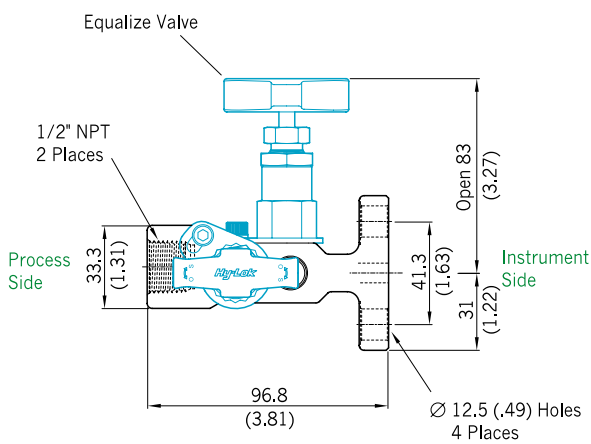
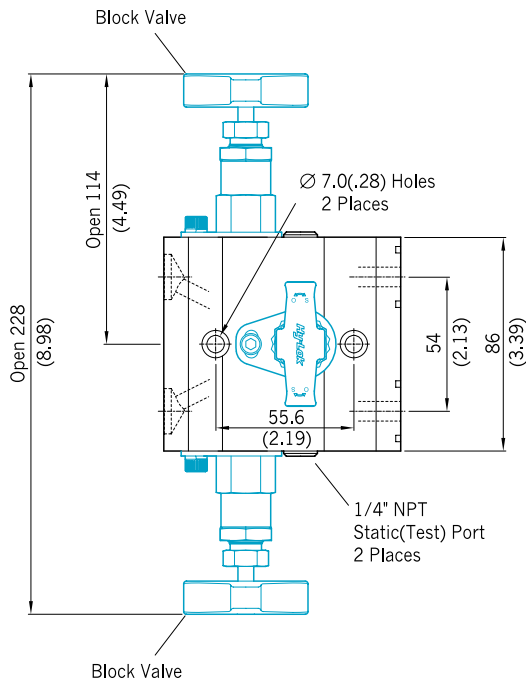

All dimensions are in millimeters(inches) reference only, subject to change.

Instrument Manifold

3-Valves Single Block Flange

M3VDM ** 8N

1.7 kg (3.8 lb)

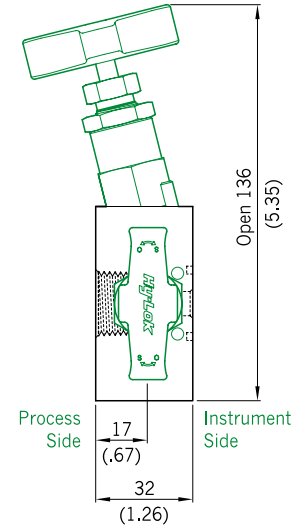
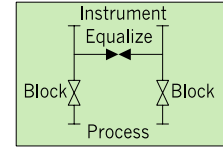
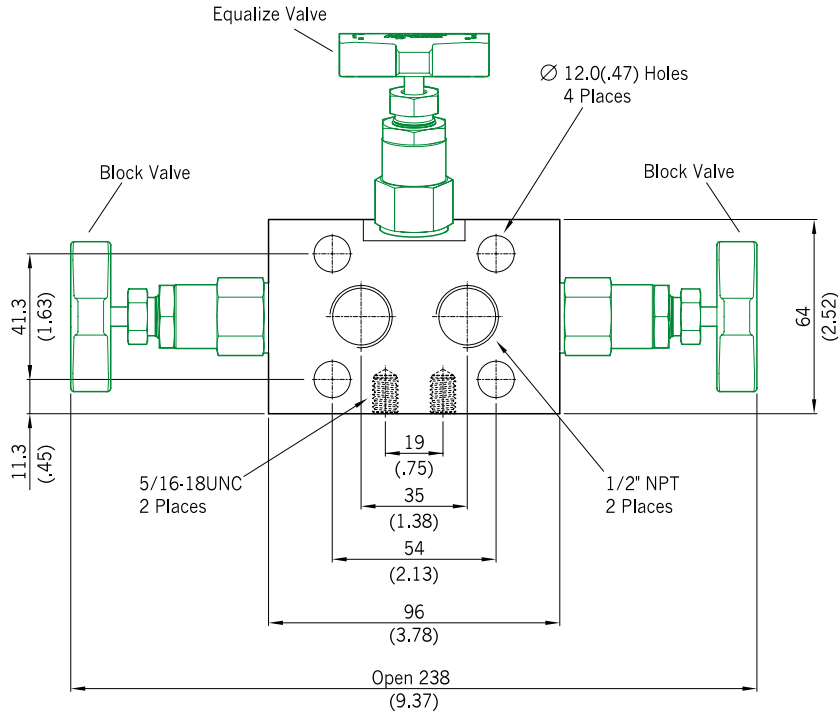

3-Valves Dual Block Flange

M3V2DM **

1.8 kg (4.0 lb)

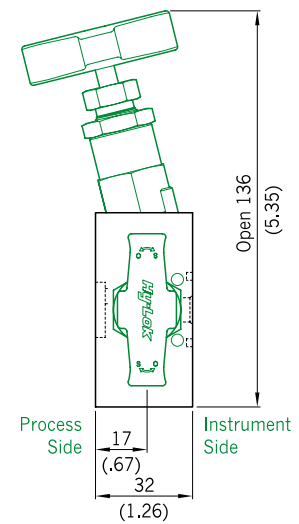
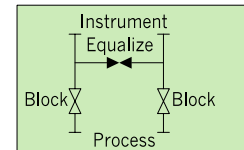
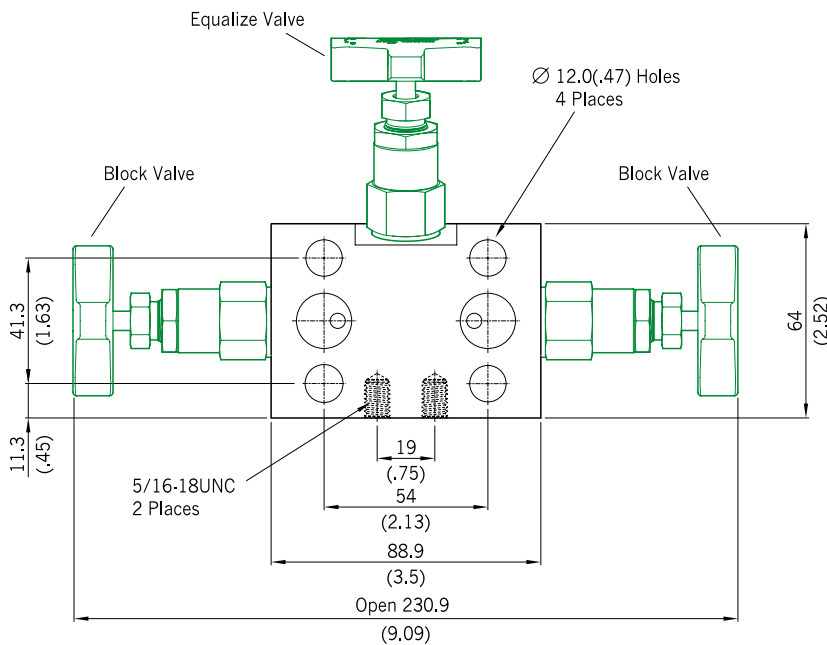

All dimensions are in millimeters(inchs) reference only, subject to change.

5-Valves Single Flange
M5V1F ** 8N
 2.7 kg (6.0 lb)

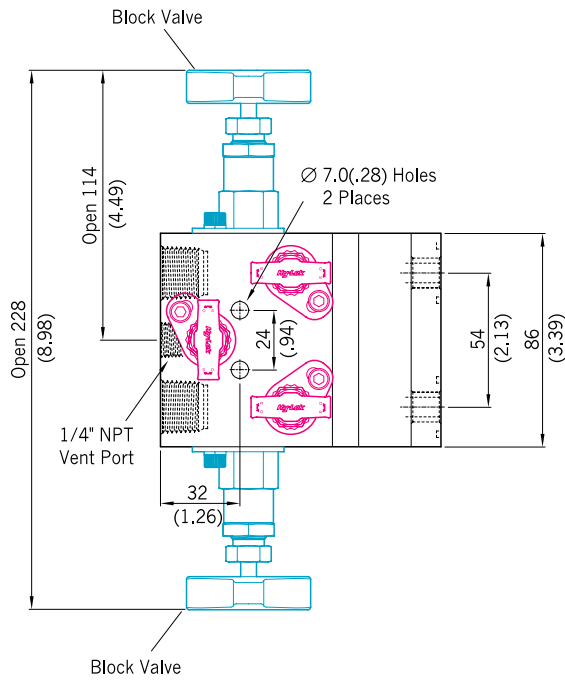

5-Valves Dual Flange
M5V2F **
 2.7 kg (6.0 lb)

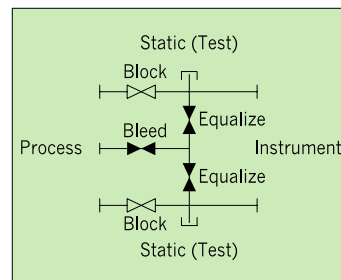
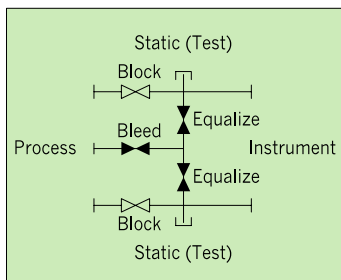
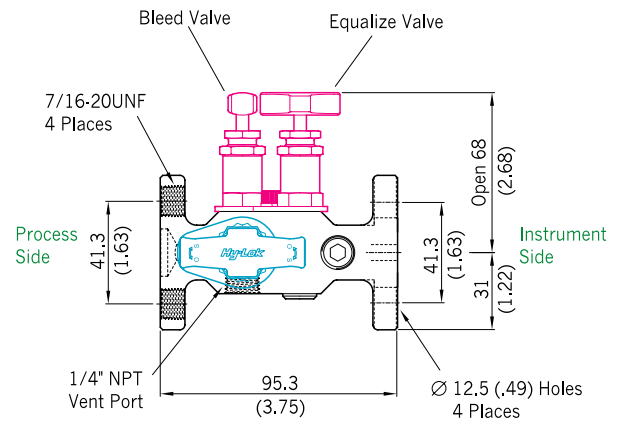
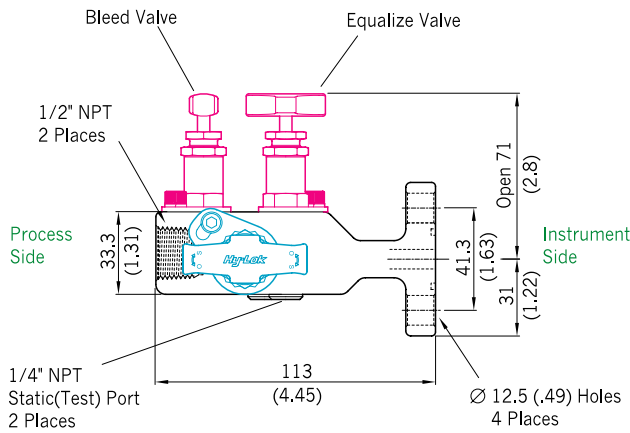
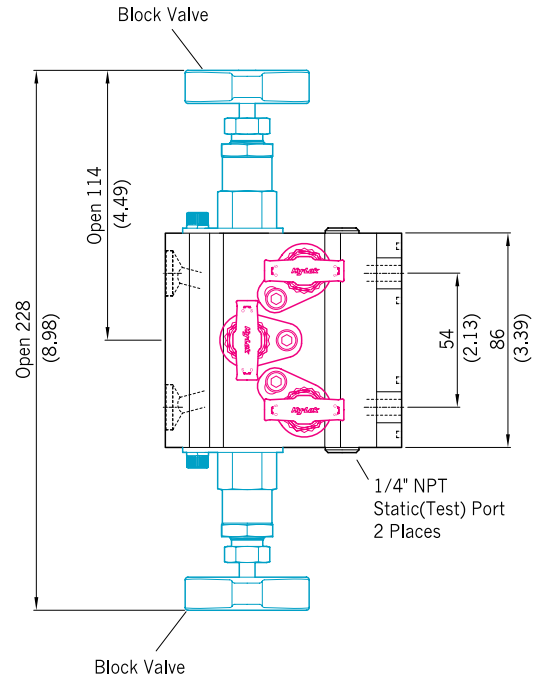

All dimensions are in millimeters(inches) reference only, subject to change.

Instrument Manifold

5-Valves Single Block Flange

M5VDM ** 8N

3.3 kg (7.3 lb)

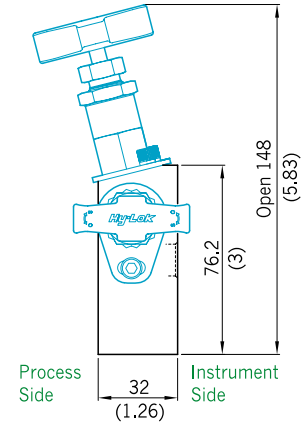
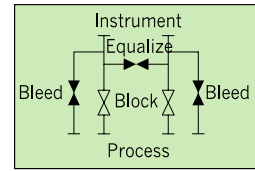
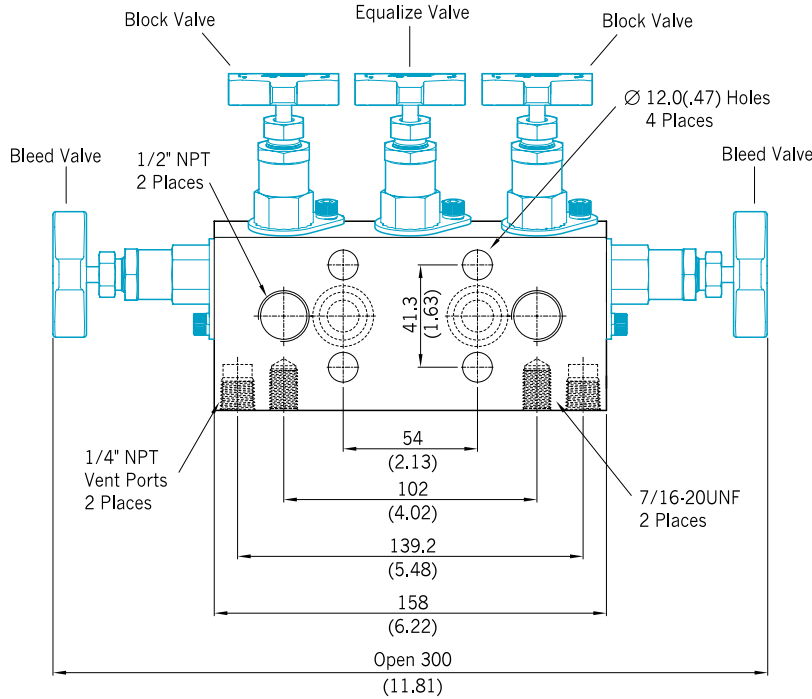

5-Valves Single Block Flange "A" style

M5VDMA ** 8N

2.7 kg (6.0 lb)

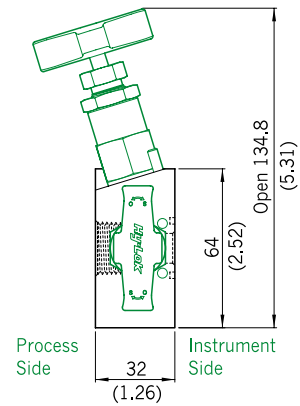
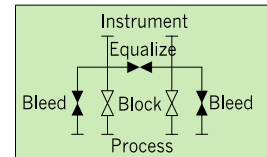
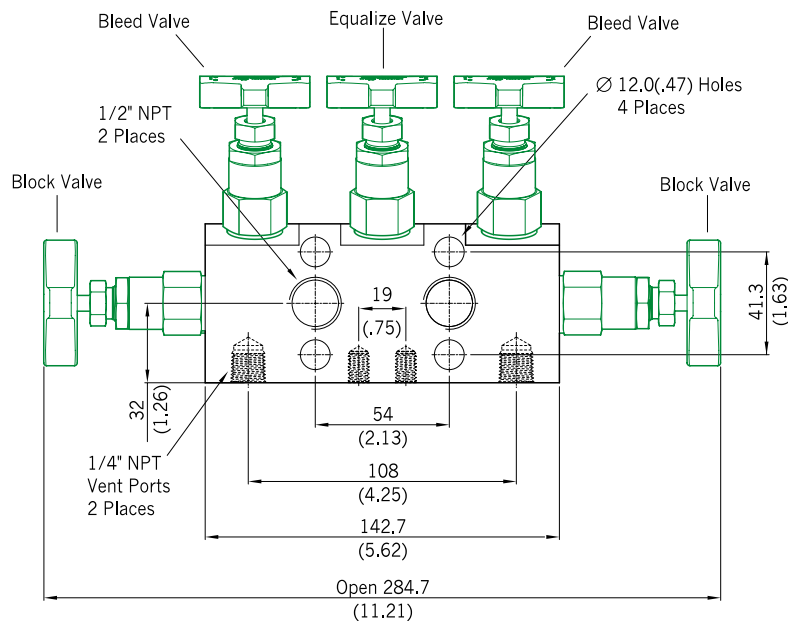

All dimensions are in millimeters(inchs) reference only, subject to change.

Gage / Root Valve

Gage Valves GV

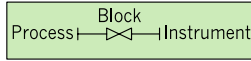

Part No.	End Connection		Dimensions				Weight (kg/lb)
	Process	Instrument	L	L ₂	H	S	
GV ** MF8N	Male NPT 1/2"	Female NPT 1/2"	90 (3,54)	87.0(3,43)	50 (1,97)	32(1,26)	0,6/1,3
GV ** MF12N8N	Male NPT 3/4"	Female NPT 1/2"		104,5(4,11)		35(1,38)	0,7/1,5
GV ** MF8N12N	Male NPT 1/2"	Female NPT 3/4"	84(3,3)	87.0(3,43)	50 (1,97)	32(1,26)	0,7/1,5
GV ** F8N	Female NPT 1/2"	Female NPT 1/2"		32(1,26)		0,7/1,5	

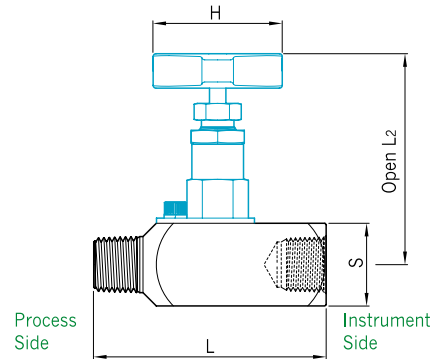

Root Valves GRV

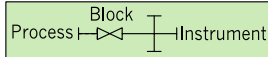

Part No.	End Connection		Dimensions				Weight (kg/lb)
	Process	Instrument	L	L ₂	H	S	
GRV** MF8N	Male NPT 1/2"	Female NPT 1/2"	136 (5,35)	87.0(3,43)	50 (1,97)	32(1,26)	0,9 / 2,0
GRV** MF12N8N	Male NPT 3/4"	Female NPT 1/2"		104,5(4,11)		35(1,38)	1,0 / 2,2
GRV** MF8N12N	Male NPT 1/2"	Female NPT 3/4"	102(4,02)	87.0(3,43)	50 (1,97)	32(1,26)	0,8 / 1,8
GRV** F8N	Female NPT 1/2"	Female NPT 1/2"		32(1,26)		0,8 / 1,8	

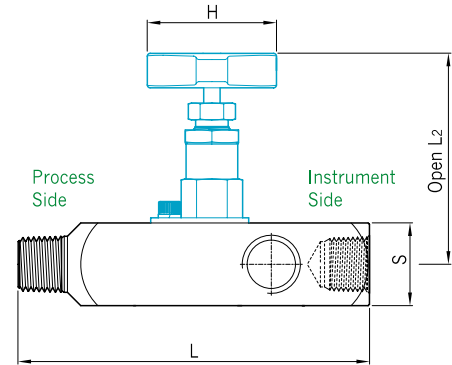

Gage 2-Valves GV2 ** - MF8N

1.2 kg (2.6 lb)

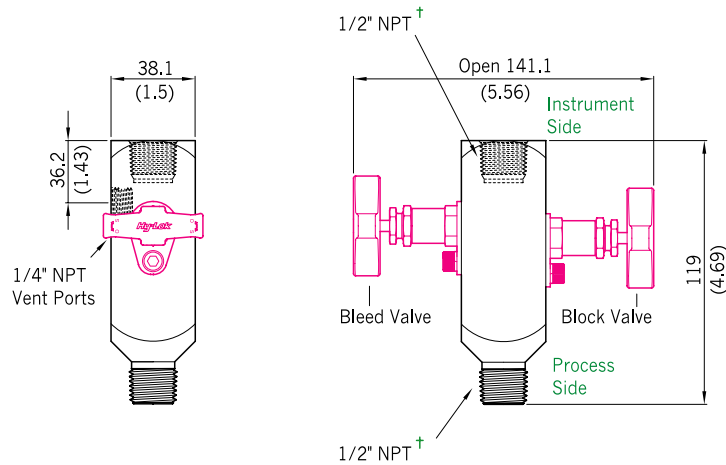
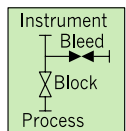

Note : "+" available in other size upon request.

Accessories

• Seals Kit



contains flange seal and stainless steel bolts

• Oval Flange kits

(Concentric / Eccentric)



contains oval flanges, seals & bolts

• Eccentric and Concentric Pipe Nipples

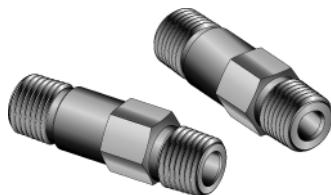

• Calibration Fittings

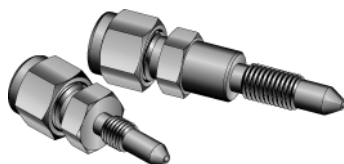

• Gage Adapter

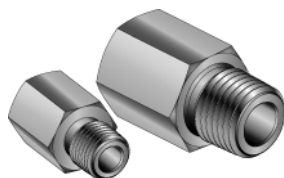

• Vent plugs, Bleed & Purge Valves

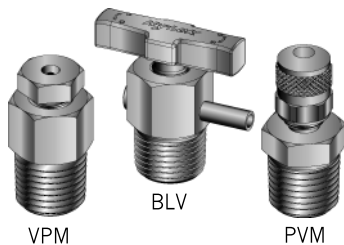

VPM

BLV

PVM

Kit Ordering Number

Basic Ordering No.	Seal Material	Temperature Range
KIT- * -V	Viton	-20 °F ~ 250 °F (-28 °C ~ 121 °C)
KIT- * -G	Grafoil	-65 °F ~ 1000 °F (65 °C ~ 537 °C)
KIT- * -P	PTFE	-65 °F ~ 450 °F (-53 °C ~ 232 °C)

* For a complete ordering number, add the desired valve and body shape designator to the basic ordering number. (See index and ordering information)
e.g KIT-M3V1F-V (3-Valve, Single flange, viton seals)

Oval flanges used to connect flange to flange manifold.

Standard connection is female NPT 1/2".

The center of eccentric flange is offset 1.6mm(1/16") from the centerline of bolt holes.

They are available in stainless steel only.

Basic Ordering Number

KIT-OCF-8N* / S316 - Concentric Flange female NPT 1/2"

KIT-OEF-8N* / S316 - Eccentric Flange female NPT 1/2"

* For a complete ordering number, add the desired seal material designator to the basic ordering number

e.g KIT-OCF-8NG / S316

Concentric and Eccentric pipe nipples have 1/2" male NPT and 76mm(3") length.

The ends of eccentric pipe nipples are offset 1.6mm(1/16") from centerline.

They are available in 316 stainless steel and carbon steel.

Basic Ordering Number

H-SCNL-8N / S316 - Concentric pipe nipple male NPT 1/2", Stainless Steel

H-SENL-8N / STEL - Eccentric pipe nipple male NPT 1/2", Carbon Steel

Calibration fittings connect directly to the bleed port of differential pressure transmitter. They are available in 316 stainless steel only.

Basic Ordering Number

CCF4-1U / S316 - Hy-Lok 1/4" - 1/4-28UNF thread

CCF4-2U / S316 - Hy-Lok 1/4" - 5/16-24UNF thread

Gage adapters connect to gage for calibration.

They are available in 316 stainless steel and carbon steel.

Basic Ordering Number

H-MFAH8N-6G-G / S316 - Male NPT 1/2" - Female ISO 228/1 3/8", Stainless steel

H-MFAH-4NG-G / STEL - Male NPT 1/4" - Female ISO 228/1 1/4", Carbon steel

Bleed & Purge valves used to vent to atmosphere and to assist in calibration

They are available in 316 stainless steel only

Basic Ordering Number

VPM - * / S316 - Vent plug Male NPT Pipe Thread

BLV - * BT / S316 - Bleed valve Male NPT Pipe Thread

PVM - * / S316 - Purge valve Male NPT Pipe Thread

* For a complete ordering number, add the desired size designator 8N(1/2"NPT) or 4N(1/4"NPT)

e.g VPM - 4N/S316 Vent plug Male 1/4"NPT

Mounting Kit



Mounting kit consist of Brackets, U-bolts, Bolt, Nut & Washer.
Mounting bracket can be vertically or horizontally mounted.
Kit material is available stainless steel and zinc plated carbon steel.

Kit Ordering Number

KIT-MMB / S304 (in case of carbon steel, KIT-MMB/ STEL)

Mounting kit & Accessories Application

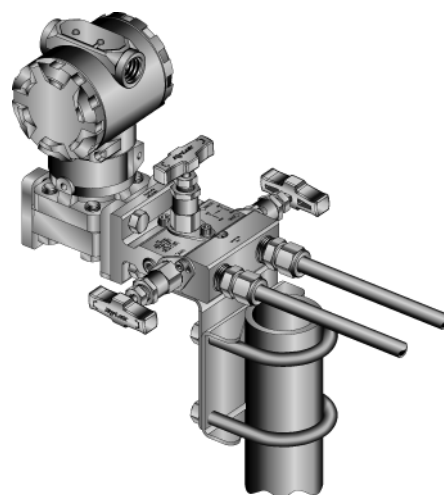

Maintenance Kits (See page 3)

Basic Ordering No.	Bonnet Type	Component	Stem Tip Shape	Designator	Packing Mat'l	Designator
KIT-MAV-SET- **	MAV	Bonnet, Stem tip, Stem, Packing,	Vee	V	PTFE	T
KIT-MBV-SET- **	MBV	Packing Washer, Packing bolt, Handle, Lock nut, Set screw,	Ball	B	Grafoil®	G
KIT-MCV-SET- **	MCV	Loking plate (pin)				

* For a complete ordering number, add the desired stem tip shape & packing material designator as a suffix to the maintenance kit basic ordering number
e.g : KIT-MBV-SET-VT (Vee tip, PTFE stem packing)

Ordering Infomation

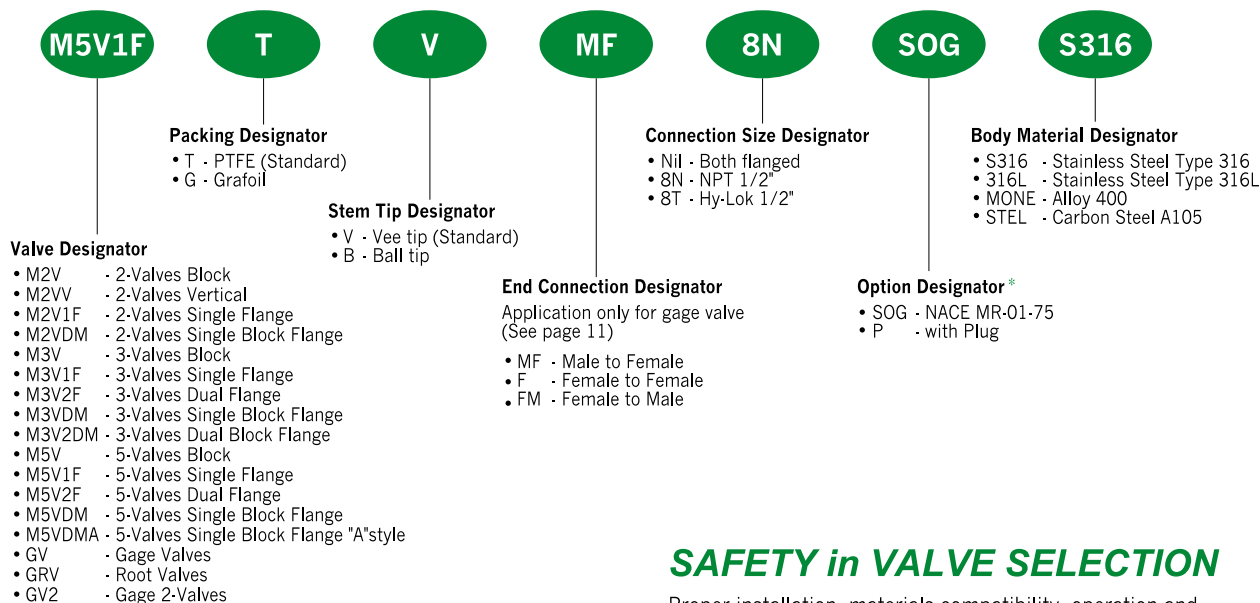

Note " * " : No designator is required for standard items, e.g. M5V1FGB8N-S316

SAFETY in VALVE SELECTION

Proper installation, materials compatibility, operation and maintenance of these valves are the responsibility of the user. The total system design must be taken into consideration to ensure optimal performance and safety

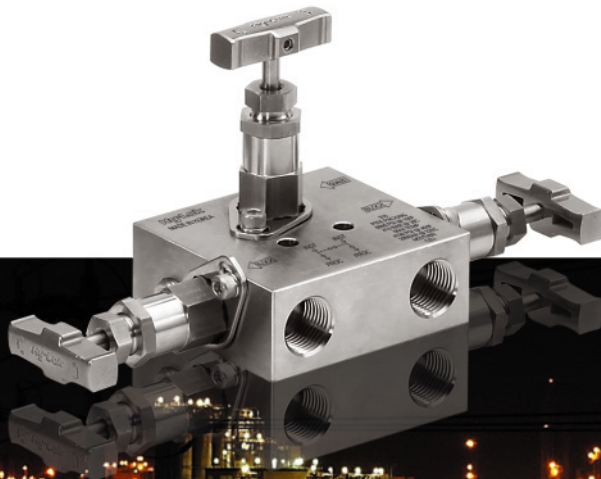

Distributed by :