

# Hy-Lok SV Series

## Integral Bonnet Bar Stock Needle Valves

Catalog No. H-101NV

Jul. 2006

### Packing Nut

- allows smooth packing adjustment

### Stem Threads

- are rolled and hard chrome-plated for maximum service life.

### Integral Bonnet

- is made from extruded bar stock and
- is available in straight and angle patterns.

### Variety of End Connections

- include Hy-Lok tube fittings, male/female NPT, male/female ISO threads.

### Best Suited Standard Handles

- include stainless steel bar, black phenolic knob, and black aluminum bar depending upon valve type.

### Packing Materials

- are available in PTFE (standard) and PEEK (option)

### Stem Tips

- include vee, and soft seat with Kel-F

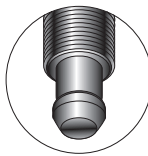
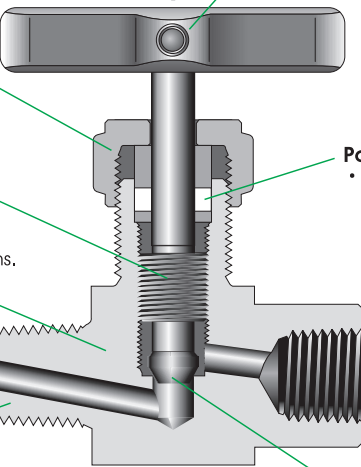

## Features

- **Pressure rating** up to 6000psig(413bar) @ 100°F(38°C)
- **Temperature rating** from -65° F to 450° F(-54° C to 232° C) with standard PTFE packing, and up to 600° F(315° C) with optional PEEK packing
- **Compact and rugged design**
- **Body materials** available in 316 stainless steel and alloy 400
- **100% factory tested**



**HY-LOK CORPORATION**

©2001, 2006 HY-LOK CORPORATION All rights reserved

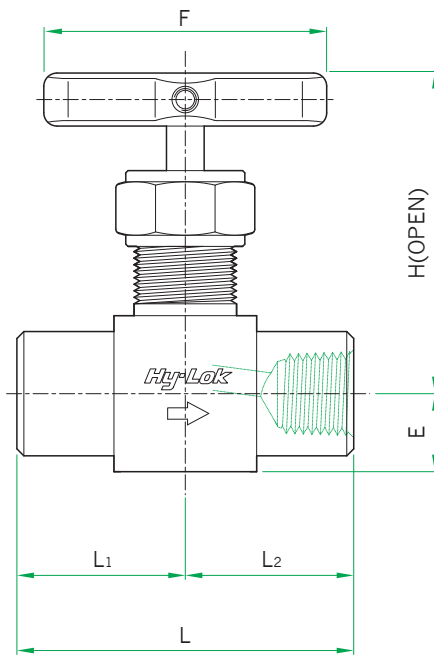

**Straight pattern**

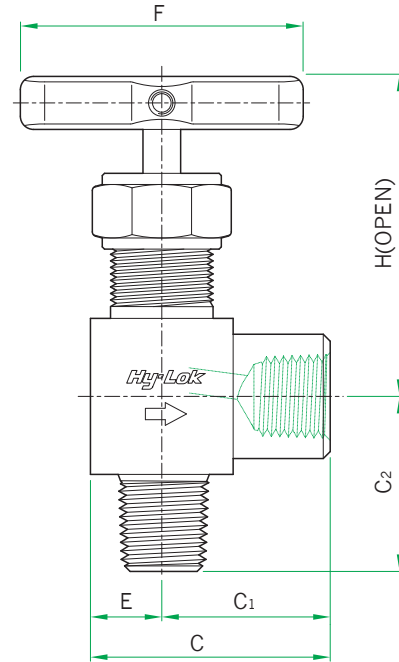

**Angle pattern**

## Table of Dimensions

Basic Part No.	Orifice Hole	Cv	End Connections		Dimensions									
			Inlet	Outlet	L	L1	L2	C	C1	C2	E	F	H	
SV1	F -4N	4.3 (0.17)	0.37	1/4" Female NPT		47.6 (1.87)	23.8 (0.94)	23.8 (0.94)	36.5 (1.44)	25.4 (1.00)	25.4 (1.00)	11.2 (0.44)	45.0 (1.77)	51.0 (2.00)
	F -4R			1/4" Female ISO										
	M -4N			1/4" Male NPT		49.2 (1.87)		24.6 (0.97)	35.8 (1.41)	24.6 (0.97)	25.2 (0.99)			
	MF -4N			1/4" Male NPT	1/4" Female NPT	48.4 (1.91)	24.6 (0.97)	23.8 (0.94)	36.5 (1.44)	25.4 (1.00)	26.2 (1.03)			
	MH-4N4T			1/4" Male NPT	1/4" Hy-Lok	53.3 (2.10)		28.7 (1.13)	39.8 (1.57)	28.7 (1.13)	29.7 (1.17)			
	H -4T			1/4" Hy-Lok		62.4 (2.46)	31.2 (1.23)	31.2 (1.23)						
SV2	F -6N	6.3 (0.25)	0.73	3/8" Female NPT		64.0 (2.52)	32.0 (1.26)	32.0 (1.26)	48.6 (1.91)	31.8 (1.25)	31.8 (1.25)	16.8 (0.66)	64.0 (2.52)	63.0 (2.48)
	F -8N			1/2" Female NPT							35.8 (1.41)			
	F -8R			1/2" Female ISO										
	MF -6N			3/8" Male NPT	3/8" Female NPT			31.0 (1.22)						
	MF -8N			1/2" Male NPT	1/2" Female NPT	64.3 (2.53)	32.5 (1.28)		35.8 (1.41)					
	MF -12N8N			3/4" Male NPT	1/2" Female NPT	63.6 (2.50)	31.8 (1.25)							
	MH-6N8T			3/8" Male NPT	1/2" Hy-Lok	73.7 (2.90)		41.9 (1.65)						
	H -6T			3/8" Hy-Lok		78.2 (3.08)	39.1 (1.54)	39.1 (1.54)						
	H -8T			1/2" Hy-Lok		83.8 (3.30)	41.9 (1.65)	41.9 (1.65)						

All dimensions in millimeters. Dimensions shown with Hy-Lok nuts in finger-tight position, where applicable.

## Technical Data

### Materials of Construction

Description	Grade/ASTM Specification		
	Valve Body Materials		
	SS 316	Alloy 400	
Handle	Stainless Steel		
Packing Nut	SS 316 / A479	Alloy R - 405 / B164	
Packing*	PTFE(TFE)		
Metal Gland	SS 316 / A479	Alloy R - 405 / B164	
Stem*	Vee	SS 316 / A479	Alloy R - 405 / B164
	Soft Seat		
Soft Tip*	Kel-F(CTFE)		
Body*	SS 316 / A479	Alloy R-400/B164	

**Note** : "\*"marked are wetted parts.  
Nickel anti-seize lubricant on non-wetted parts.

### Temperature vs Working Pressure

Temperature	Pressure (psig) @ Temperature Rating		
	ANSI Group	2.2	3.4
	Materials	SS 316	Alloy 400
	ANSI Class	2500	2500
-65° F (-54° C)	100° F ( 38° C)	6000	5000
200° F ( 93° C)		5160	4400
300° F (148° C)		4660	4120
350° F (176° C)		4470	4050
400° F (204° C)		4280	3980
450° F (232° C)		4130	3970

- To determine Kpa, multiply psig by 6.89 and bar by 0.0689
- When valves with Hy-Lok fitting end connection are connected to tubing, the working pressure of tubing must be considered in the calculation of total system working pressure.

### Sour Gas Service

- is provided to meet NACE Standard MR-01-75.

### Testing

- Each valve is tested with nitrogen @ 1000psig(69bar) to max leak rate of 0.1SCCM.
- Hydrostatic shell test is performed at 1.5 times the working pressure.
- Optional tests are available upon request.

### Temperature and Pressure Rating

Body Material	Stem Tip	Temperature Rating	Pressure Rating @-65° F ~ 100° F (-54° C ~ 38° C)
316 Stainless Steel	Vee	-65° F ~ 450° F (-54° C ~ 232° C)	6000 psig
	Soft Seat (Kel-F)	-65° F ~ 200° F (-54° C ~ 93° C)	
Alloy 400 (monel)	Vee	-65° F ~ 450° F (-54° C ~ 232° C)	5000 psig
	Soft Seat (Kel-F)	-65° F ~ 200° F (-54° C ~ 93° C)	

- The above ratings are for a standard valve with PTFE packing. For optional packing materials, refer to the table shown below.
- Extreme temperature fluctuations may require packing adjustment.

### Packing and Body Materials vs Temperature and Pressure Rating

Packing Material	Body Material	Temperature	Pressure @ Temp. Rating
PTFE (Standard)	316 Stainless Steel	-65° F ~ 450° F (-54° C ~ 232° C)	4130 psig
	Alloy 400*		3970 psig
PEEK†	316 Stainless Steel	-65° F ~ 600° F (-54° C ~ 315° C)	3760 psig
	Alloy 400*		3960 psig

\* Not applicable over 500° F(260° C)

† PEEK is not recommended for service with aromatic heat transfer fluids or concentrated sulfuric and nitric acids. Other limitations may apply.

### Handles

- Stainless steel bar handle is standard.
- Black phenolic knob is standard for soft seat stem valves.
- Black aluminum bar handles are available as an options.

### Flow Coefficient (Cv) vs Number of Handle Turns

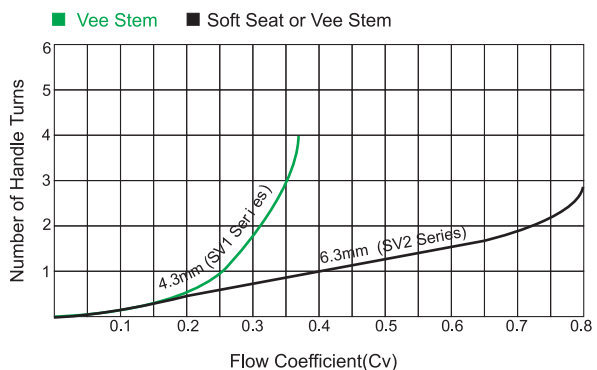

## Ordering Information

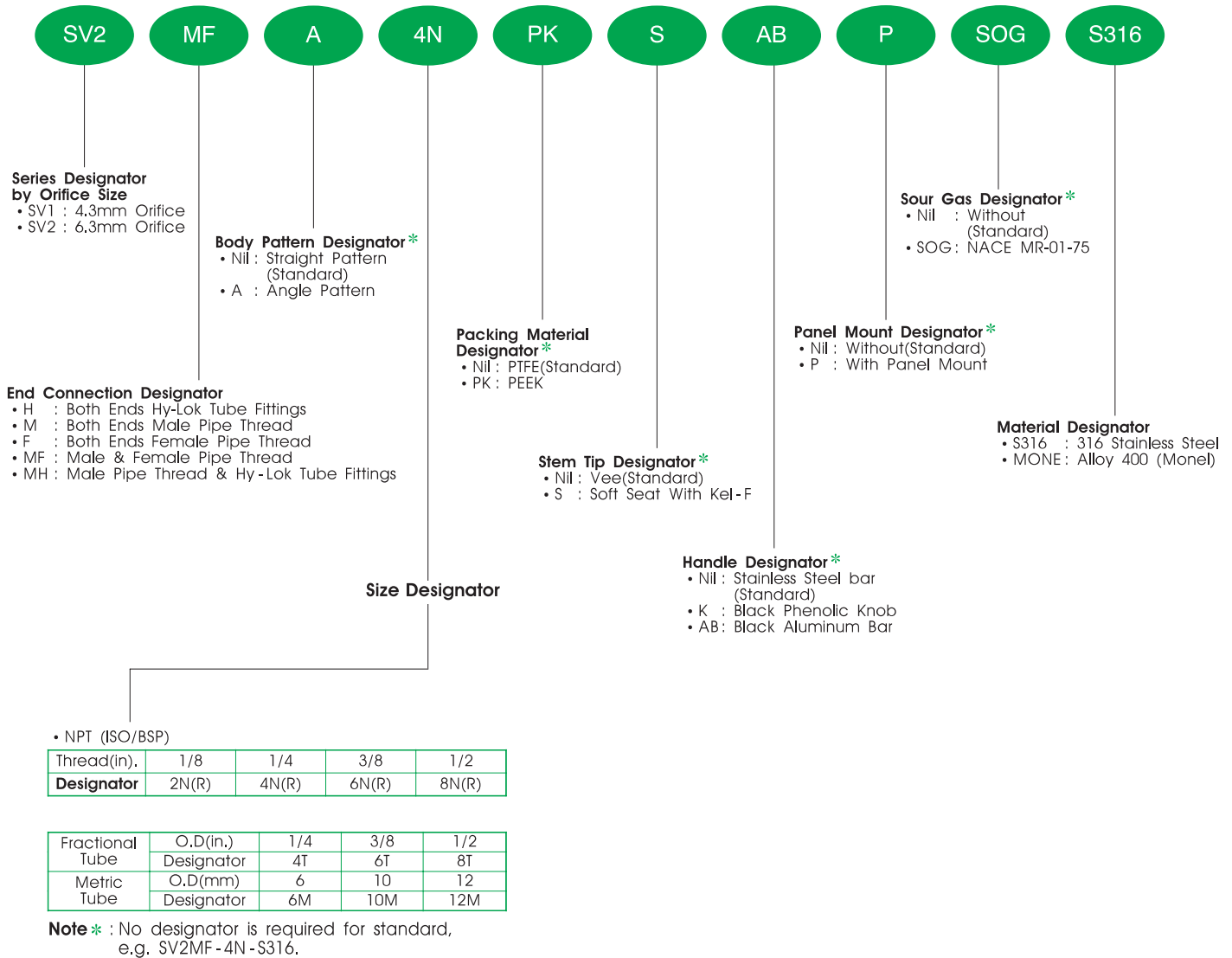

## SAFETY in VALVE SELECTION

Proper installation, materials compatibility, operation and maintenance of these valves are the responsibility of the user. The total system design must be taken into consideration to ensure optimal performance and safety.