

Hy-Lok 102 Series

Forged High Pressure Ball Valves

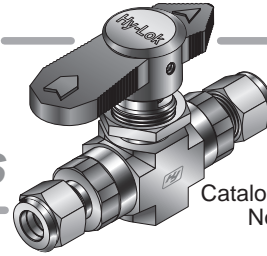

Catalog No. H-102BV
Nov. 2013

Packing bolt and Stem packing

- allow easy packing adjustment with valve in-line
- chevron packing standard for positive leak tight

Retainer seal

- is positive leak tight and prevents to wear for seat

Variety of End connections

- include Hy-Lok tube fittings, male & female NPT, male & female ISO threads

Orifice

- is optimized for min. pressure drop
- ranges from 4.2mm(0.16") to 10.3mm(0.4")

Floating ball design

- ensures leak proof shut-off in pressure and switching

Handle with arrow

- indicates flow direction
- low torque and quick operation
- available in black(standard) and colored nylon handle(option)

Panel mounting nut

- allow easy installation(standard)

Seat retainer

- with PCTFE seats standard
- is standard for easier replacement

End packing

- is machined PTFE standard

Forged body

- is available in straight(2-way) and switching(3-way)

Features

- Pressure rating up to 6000psig(413 Bar) @70°F(21°C) with PCTFE seats
- Temperature rating from -65°F to 350°F(-54°C to 177°C)with standard PCTFE seat
- Compact design
- Straight through design for max flow rate
- Body materials available in 316 stainless steel and brass
- 100% factory tested

Technical Data

Seats and Body Materials vs Temperature and Pressure Rating

Seat Material	Temperature Rating	Pressure Rating @ 100°F(38°C)		Pressure Rating@Max. Temperature	
		Stainless Steel	Brass	Stainless Steel	Brass
PCTFE	-65°F to 300 °F (-54°C to 148°C)	6000 psig (413 bar)	3000 psig (207 bar)	1000psig@300°F (68.9bar@148°C)	700psig@300°F (48bar@148°C)
PEEK	-65°F to 450 °F (-54°C to 232°C)	6000 psig (413 bar)	3000 psig (207 bar)	700psig@400°F (48bar@200°C)	
PTFE	-65°F to 300 °F (-54°C to 148°C)	1500 psig (103 bar)	1500 psig (103 bar)	250psig@300°F (17.2bar@148°C)	

⚠ Caution :

Pressure Rating with 3-way side ports of as inlet : 150 psig (10bar)

Testing

- Each valve is tested with nitrogen @1000psig(69 bar) to max.leak rate of 0.1SCCM.
- Optional tests are available upon request.

Material of construction

Description	Material Grade / ASTM Specification	
	Stainless Steel	Brass
* Body	Gr.316/A182	Brass
* End Connector	TP316 / A479	Brass
* Ball	TP316 / A479	
* Seat Retainer	TP316 / A479	
* Seat	PCTFE,PEEK,PTFE	
* Retainer Seal	PTFE	
* Stem	TP316 / A479	
Packing bolt	TP316 / A479	
Panel Nut	316 Stainless Steel	
* Stem Washer	316 Stainless Steel	
* Stem packing	PTFE	
* End Packing	PTFE	
Handle Set Screw	Stainless Steel	
Handle	Black nylon standard	

Note : "*" marked are wetted parts
Lubricant is silicone based.



HY-LOK CORPORATION

2-Way (Shut-Off Valve)

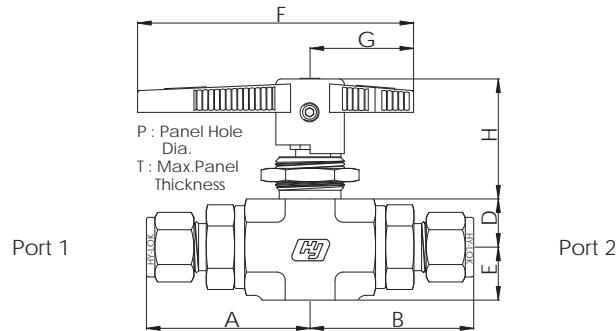

Table of Dimensions

Basic Part No.	Orifice in. (mm)	Flow Coefficient (Cv)	End Connections	Dimensions, in. (mm)																			
				Port1 & Port2	A	B	D	E	H	G	F	P	T										
HB1	H - 1T	0.052 (1.3)	0.06	1/16" Hy-Lok	1.30 (33.0)	1.30 (33.0)																	
	H - 2T	0.093 (2.4)	0.21	1/8" Hy-Lok	1.36 (34.5)	1.36 (34.5)																	
	F - 2N	0.165 (4.2)	0.93	1/8" Female NPT	1.07 (27.2)	1.07 (27.2)	0.33 (8.5)	0.39 (10.0)	0.91 (23.2)	0.71 (18.0)	1.85 (47.0)	0.64 (16.3)	0.13 (3.3)										
	M - 2N			1/8" Male NPT	1.18 (29.9)	1.18 (29.9)																	
	H - 4T			1/4" Hy-Lok	1.48 (37.6)	1.48 (37.6)																	
	M - 4N			1/4" Male	1.35 (34.3)	1.35 (34.3)																	
	H - 3M	0.086 (2.2)	0.18	3mm Hy-Lok	1.37 (34.8)	1.37 (34.8)																	
HB2	H - 2T	0.093 (2.4)	0.26	1/8" Hy-Lok	1.65 (41.9)	1.65 (41.9)	0.48 (12.3)	0.55 (14.0)	1.47 (37.4)	1.26 (32.0)	3.15 (80.0)	0.77 (19.6)	0.25 (6.4)										
	H - 4T	0.189 (4.8)	1.04	1/4" Hy-Lok	1.74 (44.2)	1.74 (44.2)																	
	F - 4N	0.250 (6.4)	2.34	1/4" Female NPT	1.51 (38.4)	1.51 (38.4)																	
	M - 4N			1/4" Male NPT	1.62 (41.1)	1.62 (41.1)																	
	H - 6T			3/8" Hy-Lok	1.80 (45.7)	1.80 (45.7)																	
	M - 6N	3/8" Male NPT	1.62 (41.1)	1.62 (41.1)																			
	H - 6M	0.188 (4.8)	1.04	6mm Hy-Lok	1.75 (44.5)	1.75 (44.5)																	
	H - 8M	0.250 (6.4)	2.34	8mm Hy-Lok	1.78 (45.2)	1.78 (45.2)																	
H - 10M	10mm Hy-Lok			1.81 (46.0)	1.81 (46.0)																		
HB3	F - 6N	0.406 (10.3)	6.42	3/8" Female NPT	1.95 (49.5)	1.95 (49.5)	0.7 (17.8)	0.77 (19.5)	1.74 (44.2)	1.50 (38.1)	4.00 (101.6)	1.02 (26.0)	0.38 (9.7)										
	F - 8N			1/2" Female NPT	2.15 (54.6)	2.15 (54.6)																	
	H - 8T			1/2" Hy-Lok	2.34 (59.4)	2.34 (59.4)																	
	M - 8N	1/2" Male NPT	2.22 (56.4)	2.22 (56.4)																			
	H - 12T	3/4" Hy-Lok	2.33 (59.2)	2.33 (59.2)																			
	H - 12M	0.375 (9.5)	5.57	12mm Hy-Lok	2.33 (59.2)	2.33 (59.2)																	
	H - 16M	0.406 (10.3)	6.42	16mm Hy-Lok	2.33 (59.2)	2.33 (59.2)																	

Dimensions in inches and (millimeters) are for reference only, subject to change. Dimensions shown with Hy-Lok nuts in finger-tight position, where applicable.

Flow Rate

Pressure Drop (Δp) to Atmosphere in psi	Cv														
	0.06	0.18	0.21	0.26	0.63	0.7	0.87	0.93	1.04	2.34	3.46	3.62	5.57	6.42	
Air@70°F (21°C) SCFM	10	5.9	17.7	20.7	25.6	62.0	68.9	85.6	91.5	102.4	230.3	340.6	356.3	548.2	631.9
	50	13.2	39.6	46.2	57.2	138.7	154.1	191.5	204.7	228.9	515.0	761.5	796.7	1225.9	1413.0
Water@60°F (16°C) US GPM	100	18.7	56.0	65.4	80.9	196.1	217.9	270.8	289.5	323.7	728.3	1077.0	1126.8	1733.7	1998.3
	10	0.2	0.6	0.7	0.8	2.0	2.2	2.8	2.9	3.3	7.4	10.9	11.5	17.6	20.3
	50	0.4	1.3	1.5	1.8	4.5	4.9	6.2	6.6	7.4	16.5	24.5	25.6	39.4	45.4
100	0.6	1.8	2.1	2.6	6.3	7.0	8.7	9.3	10.4	23.4	34.6	36.2	55.7	64.2	

* Flow rate calculated with 1000psig(69bar) inlet pressure.

* To determine m³/hr, multiply GPM by 0.227 and SCFM by 1.69.

3-Way (Switching Valve)

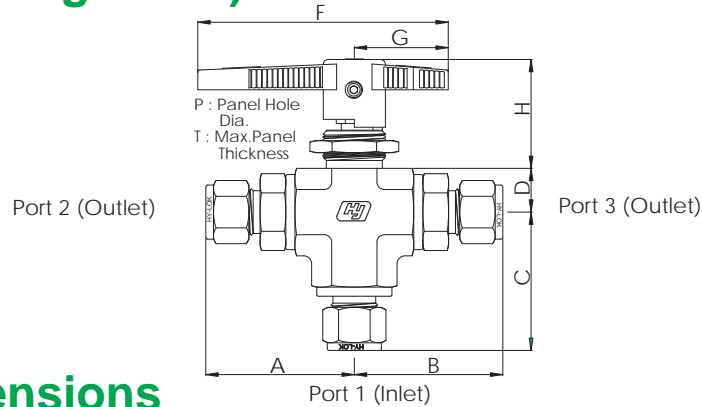

Table of Dimensions

Basic Part No.	Orifice in. (mm)	Flow Coefficient (Cv)	End Connections			Dimensions, in. (mm)							
			Port1 & Port2 & Port3	A	B	C	D	H	G	F	P	T	
HB1B3	H - 1T	0.052 (1.3)	0.06	1/16" Hy-Lok	1.30 (33.0)	1.30 (33.0)	1.33 (33.7)	0.33 (8.5)	0.91 (23.2)	0.71 (18.0)	1.85 (47.0)	0.64 (16.3)	0.13 (3.3)
	H - 2T	0.093 (2.4)	0.21	1/8" Hy-Lok	1.36 (34.5)	1.36 (34.5)	1.43 (36.4)						
	F - 2N	0.165 (4.2)	0.63	1/8" Female NPT	1.07 (27.2)	1.07 (27.2)	1.18 (29.9)						
	M - 2N			1/8" Male NPT	1.18 (29.9)	1.18 (29.9)	1.18 (29.9)						
	H - 4T			1/4" Hy-Lok	1.48 (37.6)	1.48 (37.6)	1.46 (37.2)						
	M - 4N	0.086 (2.2)	0.18	1/4" Male	1.35 (34.3)	1.35 (34.3)	1.18 (29.9)						
	H - 3M			3mm Hy-Lok	1.37 (34.8)	1.37 (34.8)	1.43 (36.4)						
HB2B3	H - 2T	0.093 (2.4)	0.21	1/8" Hy-Lok	1.65 (41.9)	1.65 (41.9)	1.56 (39.6)	0.48 (12.3)	1.47 (37.4)	1.26 (32.0)	3.15 (80.0)	0.77 (19.6)	0.25 (6.4)
	H - 4T	0.189 (4.8)	0.70	1/4" Hy-Lok	1.74 (44.2)	1.74 (44.2)	1.59 (40.3)						
	F - 4N	0.250 (6.4)	0.87	1/4" Female NPT	1.51 (38.4)	1.51 (38.4)	1.30 (33.0)						
	M - 4N			1/4" Male NPT	1.62 (41.1)	1.62 (41.1)	1.30 (33.0)						
	H - 6T			3/8" Hy-Lok	1.80 (45.7)	1.80 (45.7)	1.59 (40.3)						
	M - 6N	0.188 (4.8)	0.70	3/8" Male NPT	1.62 (41.1)	1.62 (41.1)	1.30 (33.0)						
	H - 6M			6mm Hy-Lok	1.75 (44.5)	1.75 (44.5)	1.59 (40.4)						
	H - 8M	0.250 (6.4)	0.87	8mm Hy-Lok	1.78 (45.2)	1.78 (45.2)	1.59 (40.5)						
H - 10M	10mm Hy-Lok			1.81 (46.0)	1.81 (46.0)	1.60 (40.6)							
HB3B3	F - 6N	0.406 (10.3)	3.62	3/8" Female NPT	1.95 (49.5)	1.95 (49.5)	1.85 (47.0)	0.7 (17.8)	1.74 (44.2)	1.50 (38.1)	4.00 (101.6)	0.90 (22.9)	0.38 (9.7)
	F - 8N			1/2" Female NPT	2.15 (54.6)	2.15 (54.6)	1.85 (47.0)						
	H - 8T			1/2" Hy-Lok	2.34 (59.4)	2.34 (59.4)	2.25 (57.1)						
	M - 8N	0.375 (9.5)	3.46	1/2" Male NPT	2.22 (56.4)	2.22 (56.4)	1.85 (47.0)						
	H - 12T			3/4" Hy-Lok	2.33 (59.2)	2.33 (59.2)	2.25 (57.1)						
	H - 12M	0.406 (10.3)	3.62	12mm Hy-Lok	2.33 (59.2)	2.33 (59.2)	2.25 (57.1)						
	H - 16M			16mm Hy-Lok	2.33 (59.2)	2.33 (59.2)	2.25 (57.1)						

Dimensions in inches and (millimeters) are for reference only, subject to change. Dimensions shown with Hy-Lok nuts in finger-tight position, where applicable.

Flow Rate

Pressure Drop (Δp) to Atmosphere in psi	Cv														
	0.06	0.18	0.21	0.26	0.63	0.7	0.87	0.93	1.04	2.34	3.46	3.62	5.57	6.42	
Air@70°F(21°C)	10	5.9	17.7	20.7	25.6	62.0	68.9	85.6	91.5	102.4	230.3	340.6	356.3	548.2	631.9
SCFM	50	13.2	39.6	46.2	57.2	138.7	154.1	191.5	204.7	228.9	515.0	761.5	796.7	1225.9	1413.0
	100	18.7	56.0	65.4	80.9	196.1	217.9	270.8	289.5	323.7	728.3	1077.0	1126.8	1733.7	1998.3
Water@60°F(16°C)US GPM	10	0.2	0.6	0.7	0.8	2.0	2.2	2.8	2.9	3.3	7.4	10.9	11.4	17.6	20.3
	50	0.4	1.3	1.5	1.8	4.5	4.9	6.2	6.6	7.4	16.5	24.5	25.6	39.4	45.4
	100	0.6	1.8	2.1	2.6	6.3	7.0	8.7	9.3	10.4	23.4	34.6	36.2	55.7	64.2

* Flow rate calculated with 1000psig(69bar) inlet pressure.
* To determine m³/hr, multiply GPM by 0.227 and SCFM by 1.69.

Spare Kits

•available for maintenance as below.

Kits	Components	Basic Ordering No.
HB Set ① ② ③ ④ ⑤	two PTFE end packing and retainer seal, two retainer with PCTFE seats, one set stem packing and stem washer, one handle set	KIT - * - SET
Seat Retainer ①	two retainer with PCTFE seats	KIT - * SR - PC
	two retainer with PEEK seats	KIT - * SR - PK
	two retainer with PTFE seats	KIT - * SR - P
Retainer Seal ②	two PTFE retainer seal	KIT - * - RS
End Packing ③	two PTFE end packing	KIT - * - EP
Stem Packing ④	one PTFE stem packing sets, two stem washer	KIT - * - SP
Handle ⑤	handle with screw	KIT - * HD- **

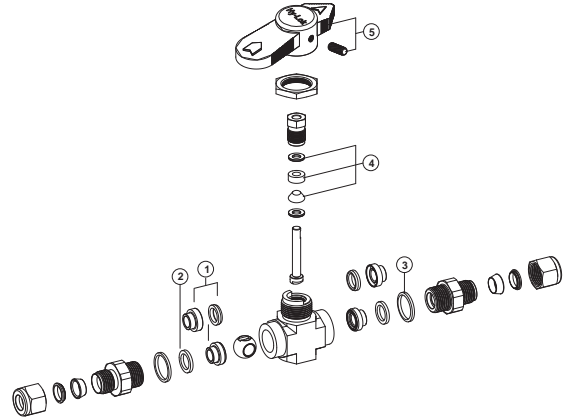

For a complete ordering number, substitute desired valve series and pattern designator for "**", color handle designator for "****". (see ordering information)
e.g. KIT - HB2HD - B (HB2 series blue color handle kit)

Ordering Information

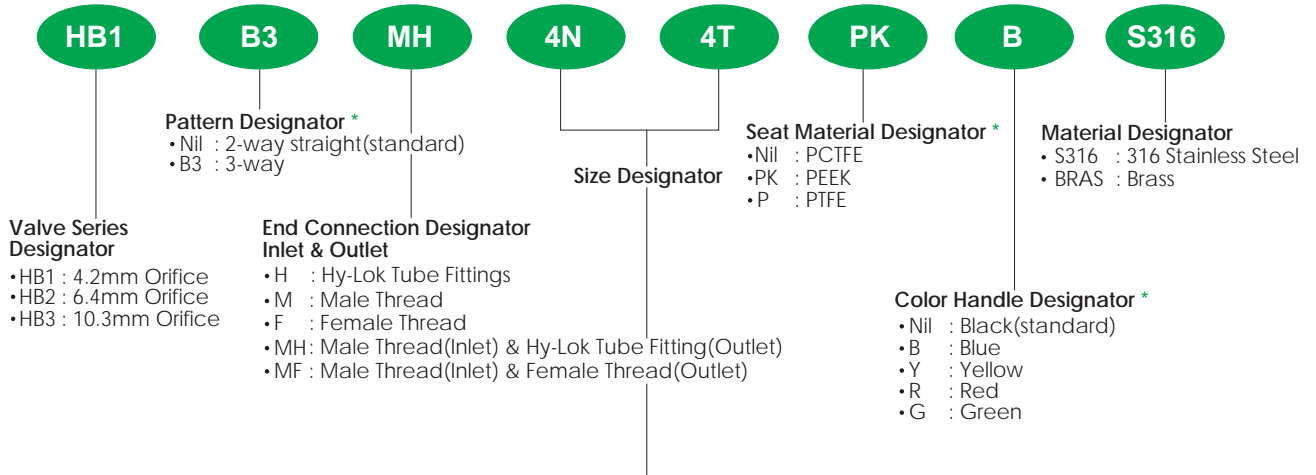

• Pipe Thread Designation NPT

Nom. Size	1 / 8	1 / 4	3 / 8	1 / 2	3 / 4
Designation	2N	4N	6N	8N	12N

• Tube O.D. Designation

Fractional Tube	Tube O.D.	1 / 16	1 / 8	1 / 4	3 / 8	1 / 2	3 / 4
	Designation		1T	2T	4T	6T	8T
Metric Tube	Tube O.D.	3mm	6mm	8mm	10mm	12mm	16mm
	Designation		3M	6M	8M	10M	12M

* No designator is required for standard.
eg. HB1MH-4N4T-S316

SAFETY in VALVE SELECTION

Proper installation, material compatibility, operation and maintenance of these valves are the responsibility of the user. The total system design must be taken into consideration to ensure optimal performance and safety.