

Hy-Lok FT Series

Micron Tee Filters



Catalog No. H-F100
May. 2010

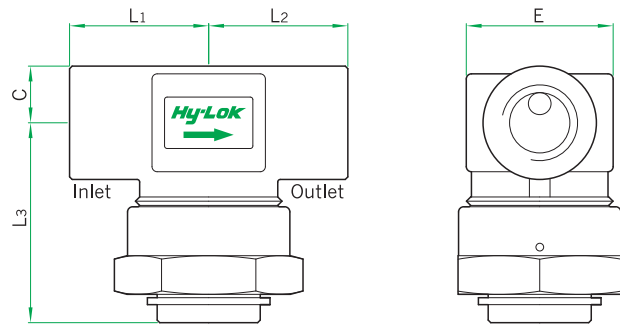
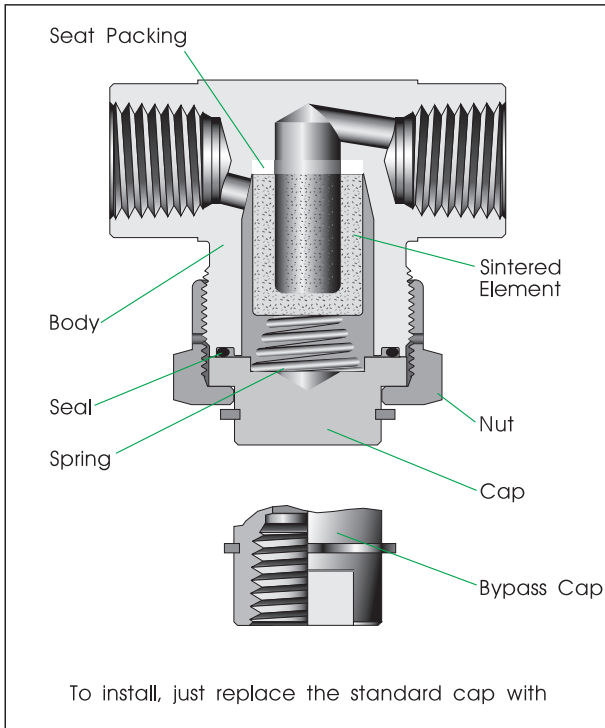

Table of Dimensions

Basic Part No.	Orifice	End Connections	Dimensions				
			Inlet & Outlet	L ₁	L ₂	L ₃	C
FT	H -4T-	1/4" Hy-Lok	33.0	33.0	38.8	11.0	28.5
	H -6T-	3/8" Hy-Lok	36.2	36.2			
	H -8T-	1/2" Hy-Lok	38.7	38.7			
	F -2N-	1/8" Female NPT	25.0	25.0			
	M -4N-	1/4" Male NPT	25.5	25.5	41.0	12.7	31.75
	F -4N-	1/4" Female NPT	27.0	27.0			
	F -6N-	3/8" Female NPT	31.0	31.0			
	F -8N-	1/2" Female NPT	31.0	31.0			

All dimensions are in millimeters.

Features

- **SS316** body material as standard
- **Replacement of filter elements** with body in line
- **Compact and robust** integral union bonnet design
- **Particle trapping** for clean fluid

Technical Data

- **Maximum Operating Pressure:**
6000 psig @ 70°F(21°C) for Stainless Steel
3000 psig @ 70°F(21°C) for Brass
- **Operating Temperature:** -60°F to 400°F (-51°C to 204°C)
- **Effective Filtration Area:**
1.73 sq. in. (0.0011 sq. meter) for all sizes.

Materials of Construction

Description	Material / ASTM Specification
Body	SS 316 - A479 or A182
Cap	SS 316 / A479
Bypass Cap	
Nut	Brass / B16
Sintered Element	316 Stainless Steel
Seat Packing	PTFE
Seal	Viton
Spring	SS 302

Filter Element and Cv

Element Micron Rating	Filtered Particle Size	Cv
1	1 micron	0.01
10	10 micron	0.02
50	50 micron	0.11
100	100 micron	0.30
150	150 micron	0.42

Operation and Filter Replacement

The filter element, which is made of sintered stainless steel, is porous and has lots of tiny holes. The particles bigger than the holes are not allowed to pass through, hence clean fluid. After certain period, the holes may be blocked by particles and pressure drop will increase. This depends upon the total flow through elements and cleanliness of upstream flow. The element needs to be replaced for clean fluid with minimum pressure drop.



HY-LOK CORPORATION

© 1997, 1998, 2002, 2003, 2010 HY-LOK CORPORATION All rights reserved

How to Replace the Element

1. Bleed the line to remove system pressure.
2. Unscrew the nut while holding the body steady with back-up wrench.
3. Remove the nut, cap, spring, and seal all together.
4. Remove the element out of the body and pull out the seat packing with care. It is recommended to replace the seat packing and seal at the same time.
5. Clean metal parts if necessary.
6. Insert new element into tapered bore with smooth faced tool until it seats firmly.
7. Put the seal back in place.
8. Place the spring on the cap and retighten the nut.

Bypass Cap

For sampling and purging, bypass cap is available with 1/4" female NPT threaded port.

Spares

For maintenance and changeover to bypass, the following spares are available.

Part No.	Description	Qty / Pack
KFT - F	Filter	1 pc
KFT - P	Seat Packing	1 pc
KFT - S	Seal	1 pc
KFT - B	Bypass Cap	1 pc

Pressure Drop vs Flow Rate of Air

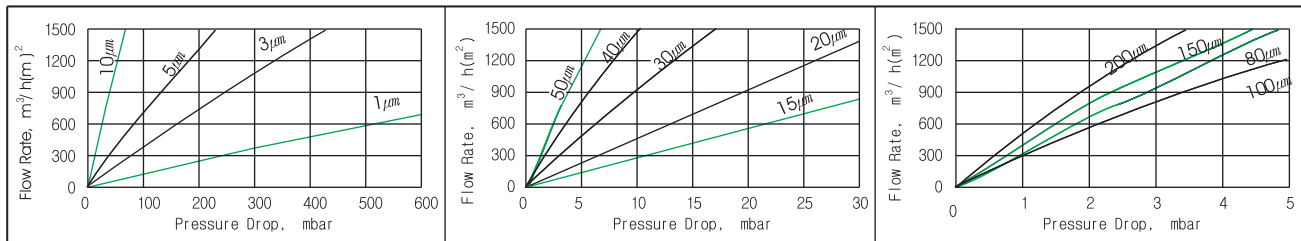

Please note the above Flow Rate is elements' co-efficient in cubic meters per hour per square meter. To get the flow rate of FT series filter, find the flow rate in the graph and then multiply it with effective filtration area on previous page.

Ordering Information

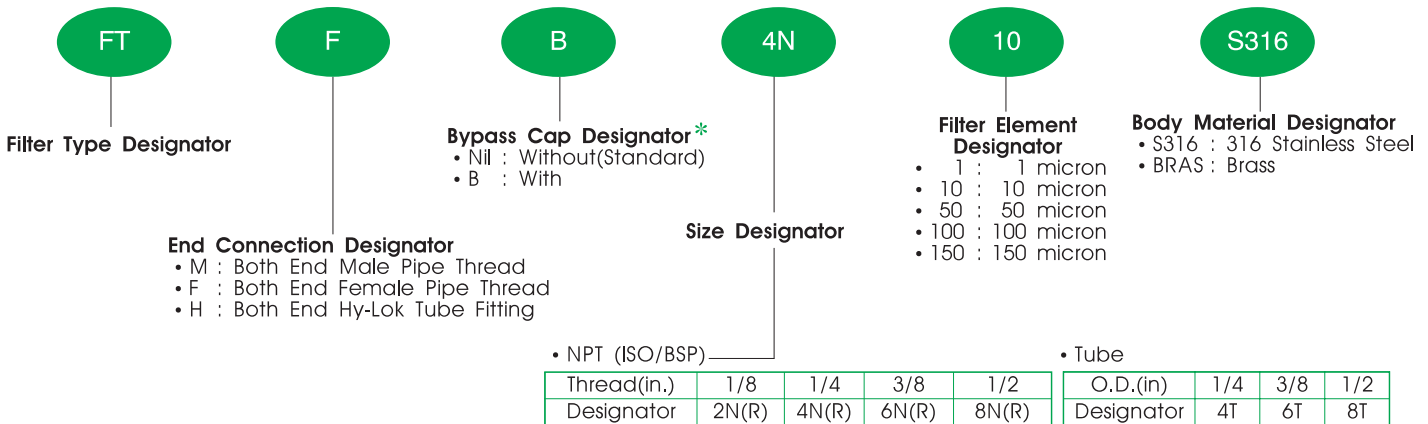

Note * : No designator is required for standard e.g. FTF-4N-10-S316

SAFETY in VALVE SELECTION

Proper installation, materials compatibility, operation and maintenance of these valves are the responsibility of the user. The total system design must be taken into consideration to ensure optimal performance and safety.